

COTEK

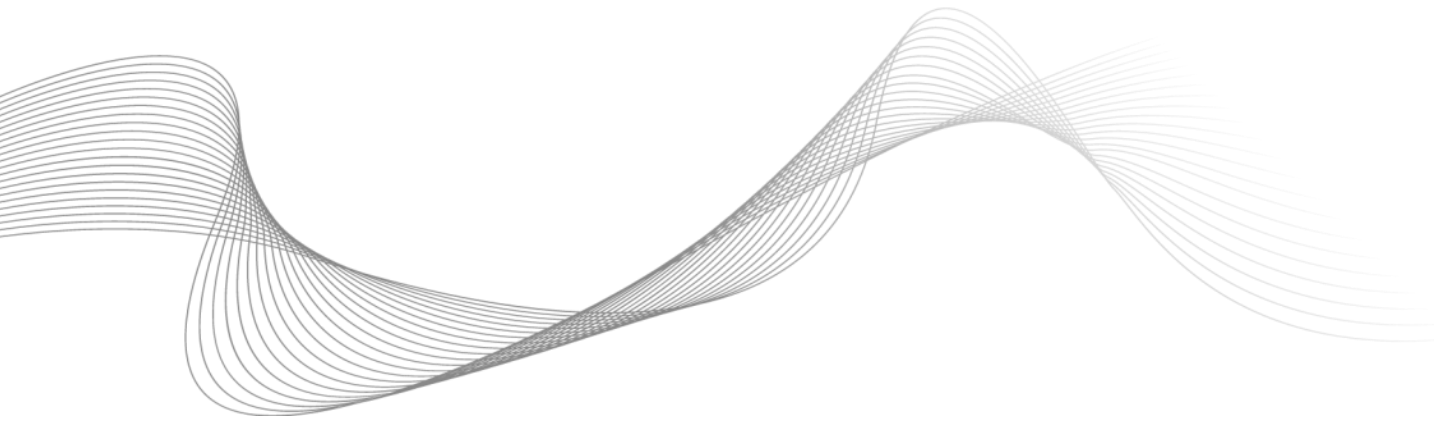

SR1000T

User's Manual

Telecom / Datacom

PURE SINE WAVE INVERTER

Table of Contents

1. IMPORTANT SAFETY INSTRUCTIONS	1
1-1. General Safety Precautions	1
1-2. Additional Safety Notes	2
1-3. Rack-Mounted Installation	3
2. FUNCTIONAL CHARACTERISTICS INTRODUCTION	4
2-1. System	4
2-2. Block Diagram	5
2-3. Electrical Performance	6
2-4. Mechanical Drawings	7
3. INSTALLATION AND MAINTENANCE	8
3-1. Front Panel	8
3-2. Rear Panel	9
3-3. DC Input Connection	錯誤! 尚未定義書籤。
3-4. AC Wiring Connections	錯誤! 尚未定義書籤。
3-5. Remote Control and Dry Contact Terminal	錯誤! 尚未定義書籤。
3-6. Operation	錯誤! 尚未定義書籤。
3-7. Maintenance	錯誤! 尚未定義書籤。
4. FRONT LCD PANEL – DISPLAY & SETUP	17
4-1. LCD Panel Indications	錯誤! 尚未定義書籤。
4-2. Startup Sequence and Standby Status	錯誤! 尚未定義書籤。
4-3. Setup Menu – Operation and Instructions	錯誤! 尚未定義書籤。
5. RS-232 COMMUNICATION AND OPERATION	24
5-1. Operation of RS-232 Serial Port	24
5-2. Interface Commands	24
5-3. Example of the RS-232 Operation	25
6. LED STATUS DESCRIPTION & TROUBLE SHOOTING	30
6-1. Troubleshooting	30
6-2. Warranty	30

1. Important Safety Instructions



WARNING!

SAVE THESE INSTRUCTIONS – This manual contains important instructions that should be followed during installation and maintenance of the inverter.

1-1. General Safety Precautions

1-1-1. Do not expose the inverter to rain, snow, spray or dust.

To reduce the risk of a fire hazard, do not cover or obstruct the ventilation openings and do not install the inverter in a zero-clearance compartment.

1-1-2. To avoid the risk of fire and electric shock, make sure that the existing wiring is in good electrical condition; and that the wire size is not undersized.

Do not operate the inverter with damaged or substandard wiring.

1-1-3. Depending on the application, the AC output of the inverter may require user installed breaker or fuse. For telecom use, a GFCI has not been provided.

The inverter incorporates standard AC short circuit protection.

1-1-4. The following precautions should be taken when working on the inverter :

- Remove watches, rings, or other metal objects.
- Use tools with insulated handles.
- Wear rubber gloves and boots.

1-1-5. If one of the following situations arises, get the equipment checked by service personnel :

- Liquid has penetrated into the equipment.
- The equipment has been exposed to moisture.
- The equipment does not work well or you cannot get it to work according to the user manual.
- The equipment has been dropped and damaged.
- If the equipment has an obvious sign of breakage.

1-2. Additional Safety Notes

- 1-2-1. Upon receipt, inspect the shipping carton for damage. Notify the carrier immediately, before opening, if damage is evident.
- 1-2-2. Do not operate near water or in excessive humidity.
- 1-2-3. Do not open or disassemble the inverter, warranty may be voided.
- 1-2-4. The DC side connections should be firm and tight.
- 1-2-5. Grounding : Reliable grounding of rack-mounted equipment should be maintained.

- 1-2-6. Do not drop a metal tool on the battery. The resulting spark or short circuit on the battery or other electrical parts may cause an explosion.
- 1-2-7. Install the inverter in a well-ventilated area. Do not block the front air vents, or the rear air exhausts of the unit. Use a vacuum cleaner to remove any dust from the fan area.
- 1-2-8. Wiring : Adequate input power must be supplied to the inverter for proper use; and correct wiring sizes must be ensured.
- 1-2-9. Mount the inverter such that the fan axis is horizontal.
- 1-2-10. Do not operate the inverter close to combustible gas or open fire.
- 1-2-11. Do not operate appliances that may feed power back into the inverter.
- 1-2-12. Temperature : The inverter should be operated in an ambient temperature range of 0°C to 50°C , otherwise the output efficiency may be affected. Air flow to the inverter must not be restricted.
- 1-2-13. When cleaning the case or front panel, use a soft, dry cloth, only. If the case or front panel is very dirty, use a neutral, non-abrasive detergent. Do not use alcohol or ammonia based solutions.
- 1-2-14. Regular servicing, and relocation of the inverter, should be performed by a qualified service technician.
- 1-2-15. Avoid spilling liquid on the inverter.

1-3. Rack-Mounted Installation

Rack-Mounted Equipment – The unit is intended to be rack-mounted, and the installation instructions should address the following concerns when the unit is mounted in a rack system.

- 1-3-1. The equipment is to be installed in an environment where the maximum ambient temperature must not exceed 50°C.
- 1-3-2. The openings on the enclosure are for air convection hence protecting the equipment from overheating. **DO NOT COVER THE OPENINGS.**
- 1-3-3. Place the equipment on a stable surface during installation. Dropping or falling could cause injury.
- 1-3-4. The equipment shall be installed according to specification on the nameplate. Ensure the voltage of the power source when connecting the equipment to the power outlet. The current of the load and the output power of loads should not exceed the specifications.
- 1-3-5. This equipment must be connected to reliable earthing before use.
- 1-3-6. "Equipment intended for installation in Restricted Access Location" and input DC terminal at back of the rack to prevent qualified service personnel from touching it.

2. Functional Characteristics Introduction

2-1. System

The unit is a highly reliable DC-AC inverter system, designed with advanced power electronic and microprocessor technology offering the following features :

- The inverter is equipped with a self-diagnosis microprocessor that can identify and display all failure messages on the LED/LCD display, accompanied by visual/audio alarms.
- 1U height x 19" width x 13.6" depth, 19" rack mounting.
- Pure sine wave output (THD < 2%) to operate high-end electronic equipment.
- Built in 15A(120VAC) and 10A(250VAC) rated bypass relay.
- Speeds up transfer time as a result of synchronized operation with the AC source at all times, allowing interruption-free transfer for sensitive equipment.
- Intelligent software for power management.
- Loading and temperature controlled cooling fan.
- Fan aging, failure, disconnection and blockage alarm.
- Selectable bypass/Inverter modes.
- Local and remote management and control.
- RS-232 communication.
- Dry contact terminal.
- Efficiency >90%. (Full linear load at 220VAC Output)
- Advanced Protection Features :
 - Input over/under voltage protection.
 - Internal over temperature protection.
 - Input reverse polarity protection (Fuse).
 - Output overload protection.
 - Output short circuit protection
 - AC input short circuit protection : Breaker (6 Amp or 12 Amp)

2-2. Block Diagram

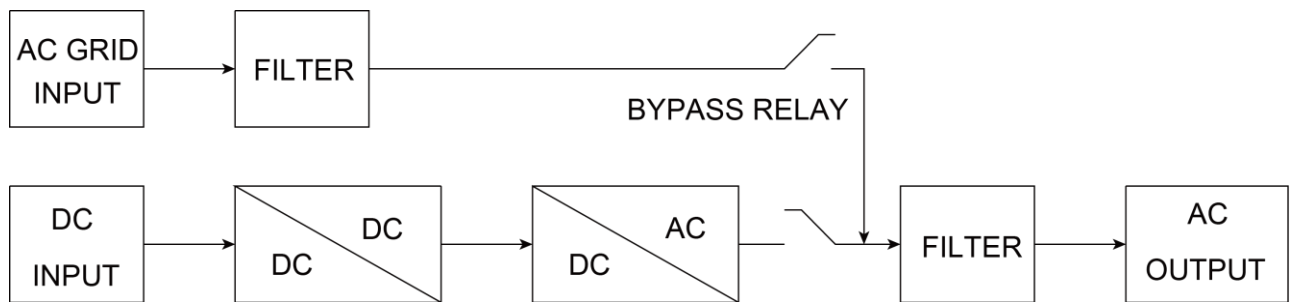

The inverter features IGBT technology which, minimizes weight and dimensions while enhancing output short circuit reliability and overload capacity.

AC output voltage is provided in one of the two modes :

1. From DC to AC Inverter Mode : (DC mode)
2. From AC Input Bypass mode : (AC mode)

Either mode is programmable from the front panel.

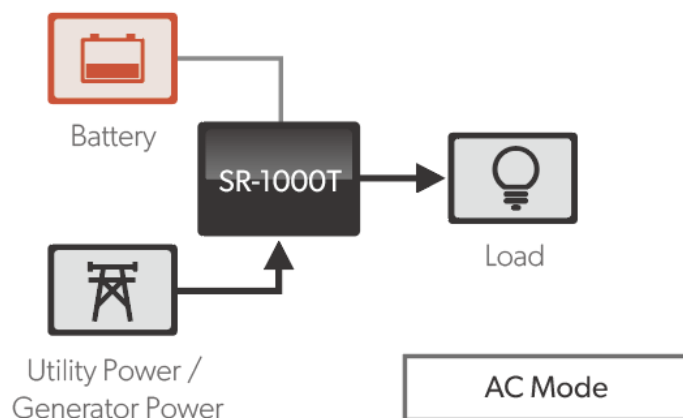
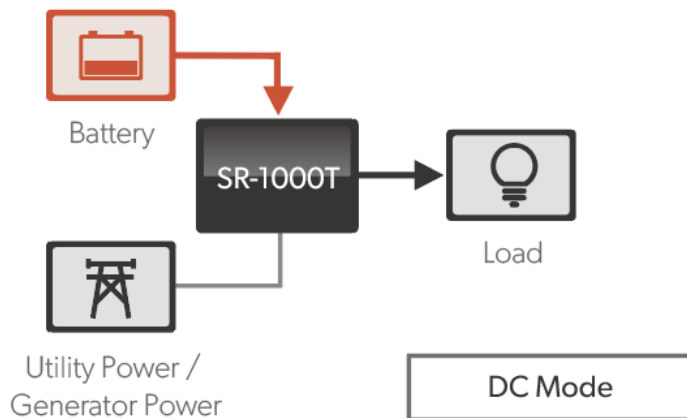

2-3. Electrical Performance

Electrical	Specification	Model No.			
	Item	SR1000(T)-124	SR1000(T)-148	SR1000(T)-224	SR1000(T)-248
Output	Continuous Output Power	1000W			
	Maximum Output Power (3 Min)	1100W			
	Surge Power	2000W			
	Frequency (Adjustable)	47~63Hz ± 0.5%			
	Nominal Voltage	110VAC		230VAC	
	Output Voltage Range (Adjustable)	97~123VAC		194~246VAC	
	Efficiency (Full Load)	87%	88%	90%	91%
	Output Waveform	Pure Sine Wave (THD<2%)			
Input	Nominal Voltage	24VDC	48VDC	24VDC	48VDC
	Voltage Range (Default)	18~34VDC	36~60VDC	18~34VDC	36~60VDC
	Voltage Range (Adjustable)	18~34VDC	36~68VDC	18~34VDC	36~68VDC
	No Load Current	1.4A	0.75A	1.3A	0.7A
Signal and Control	LCD Panel	2 Lines LCD panel with keypad for navigation			
	LED Indicator	Red / Orange / Green LED			
	Dry Contact Terminal	By a relay			
	Remote Control Terminal	Controls the inverter ON / OFF operation			
Protection	Input Protection	Over / Under voltage, reverse polarity (Internal fuse)			
	AC Output Protection	Short-circuit, overload			
	AC Input Protection	12 Amp circuit breaker		6 Amp circuit breaker	
	Temperature Protection	Shutdown (Internal temperature $\geq 65^{\circ}\text{C}$)			
Bypass Relay	Relay Specification	15 Amp / 120VAC, 10 Amp / 250VAC			
	Bypass relay selectable	On Line / Off Line (Haphazard, Normal, Exacting) selectable			
	Switching Time	From AC Bypass mode (Offline mode) : $\leq 20\text{mS}$ From DC to AC inverter mode (Online mode) : $\leq 8\text{mS}$			
Environment	Working Temp.(Full load)	0°C ~ 50°C			
	Storage Temp.	-30°C ~ 70°C			
Safety & EMC	Safety Standards	Certified UL 62368-1		Certified EN 62368-1	
	EMC Standards	Certified FCC class B		EN 55032: 2015+A11:2020 EN 55035: 2017 / A11: 2020	
Fan Operation & Indicator	Failure Indicator	Buzzer alarm and dry contact			
	Switches On When	Internal Temperature $\geq 55^{\circ}\text{C}$ or Load $\geq 30\%$			
	Switches Off When	Internal Temperature $\leq 45^{\circ}\text{C}$ and Load $\leq 20\%$			
Others	Dimension (WxHxD)	483 x 44 x 395 mm / 19.02 x 1.73 x 13.55 inch			
	Packing	7.46kg; 2pcs / 15.9kg / 1.74 CUFT			
	Application	Focus on telecommunication (base-station), networking (data center) & battery backup system.			

Note : The specifications are subject to change without notice.

2-4. Mechanical Drawings

Unit : mm [inch]

2-4-1. SR1000T Mechanical Drawings

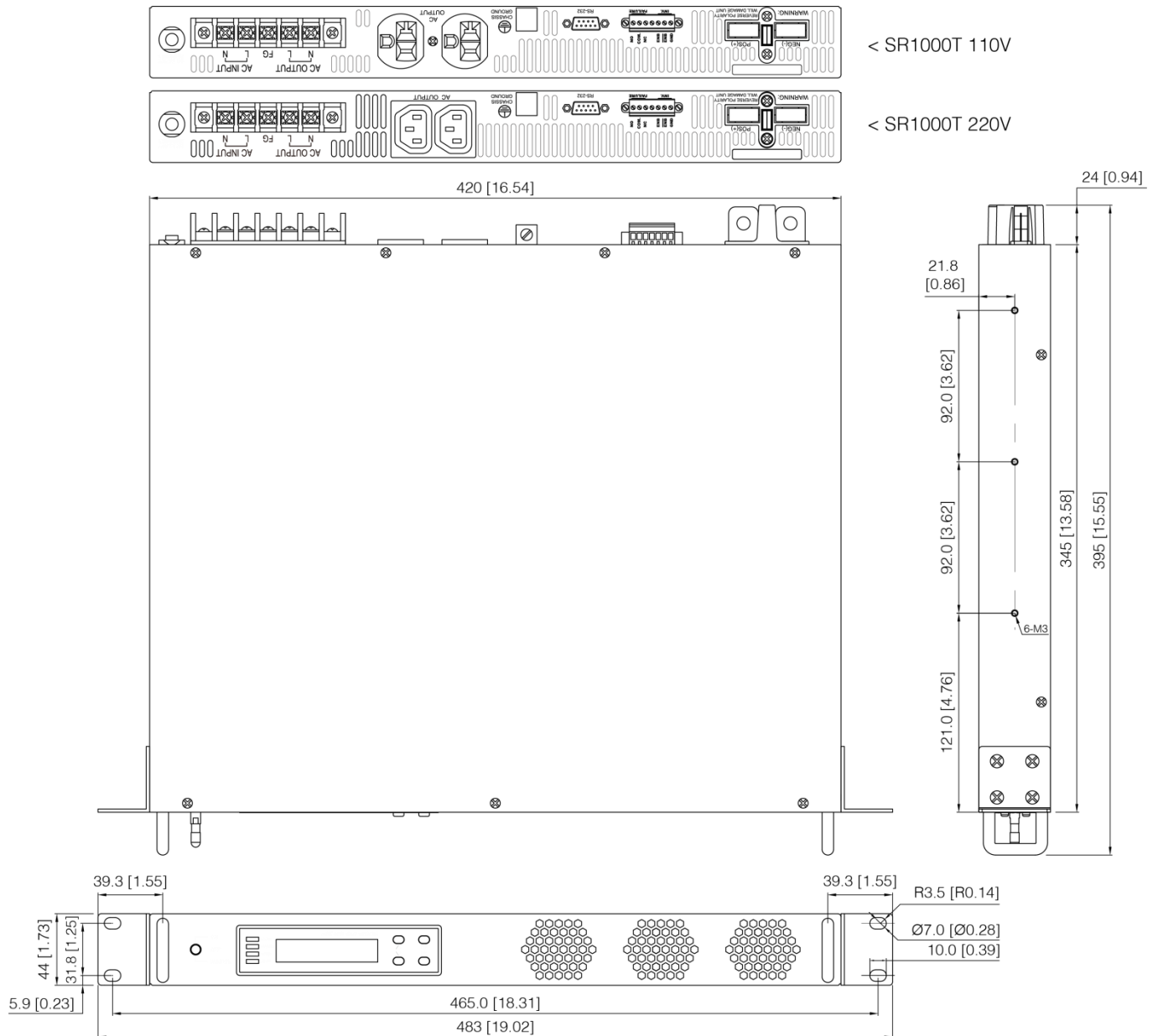

SR Series Inverter Ordering Information

Model Number	Input Voltage	Output Voltage Nominal	Output Voltage Range	Frequency Range
SR1000/SR1000T-124	24 VDC	110 VAC	100~120 VAC	47~63 Hz
SR1000/SR1000T -224	24 VDC	230 VAC	200~240 VAC	47~63 Hz
SR1000/SR1000T -148	48 VDC	110 VAC	100~120 VAC	47~63 Hz
SR1000/SR1000T -248	48 VDC	230 VAC	200~240 VAC	47~63 Hz

3. Installation and Maintenance

3-1. Front Panel

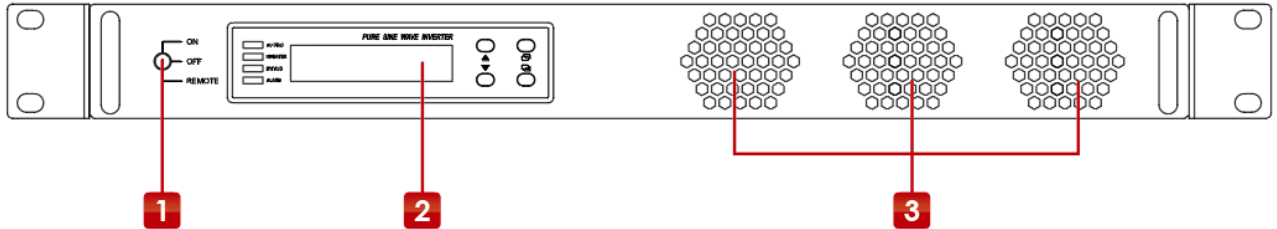

- 1 Main Switch:** These are the 3-stage rocker switches for turning on, turning off and remote mode.
- 2 Front LCD Panel:** Press these buttons to display data such as DC input voltage, AC output voltage, AC output frequency, AC output current, and system status sequentially on the LCD display. (Refer to [4-1](#))
- 3 FAN Ventilation:** The fans behind the ventilation grilles provide cooling.
DO NOT obstruct these vents!

3-2. Rear Panel

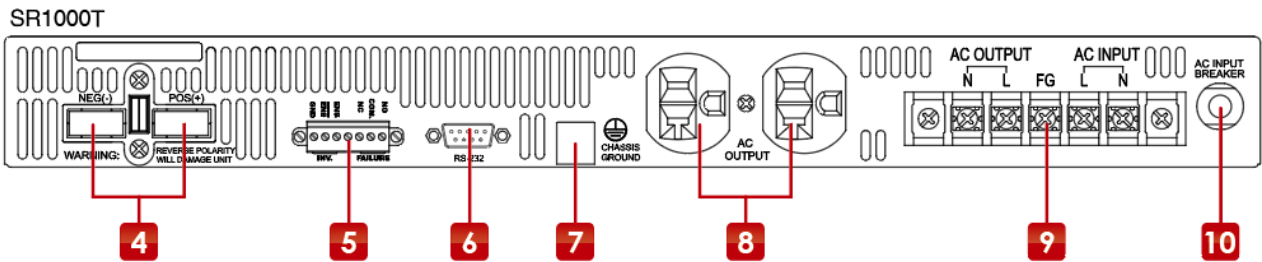

- 4 DC input:** Connect the 24V/48V battery (Refer to [3-3](#))
- 5 Remote control and Dry contact terminal** (Refer to [3-5](#))
- 6 Standard RS-232:** Serial port monitoring and control through computer interface.
(Refer to [5-1](#))
- 7 Chassis Ground:** The equipment must be connected to an earth ground before making any other connections.
- 8 AC output socket:**

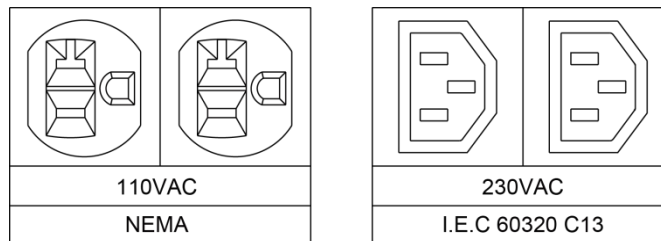

Calculate the total power consumption(W) of the output load. Ensure that the total power consumption does not exceed the rated load.

- 9 AC wiring connections** (Refer to [3-4](#))
- 10 AC input breaker:** The AC input circuit breaker protects the unit from overload. When an overload condition occurs, the circuit breaker trips and disconnects the AC grid power input. To reset it, push the circuit breaker button. Before resetting the unit, identify and correct the cause of the tripping.

3-3. DC Input Connection

The following cable size and fuses are recommended for up to 6 ft. distance between the batteries and the inverter. (Applicable to both 120 VAC and 230 VAC versions) :

Model No.	Wire AWG	Inline Fuse
SR1000/SR1000T-124 / 224	# 4	80 A
SR1000/SR1000T-148 / 248	# 6	40 A

- When connecting DC input terminals to 24V / 48V battery please note. [+] is positive, and [-] is negative. Reverse polarity connection can blow the internal fuse and may damage the inverter permanently.
- Also, only use high quality copper wire and keep the cable length as short as possible. Suggestive cable length is 3 - 6 feet.

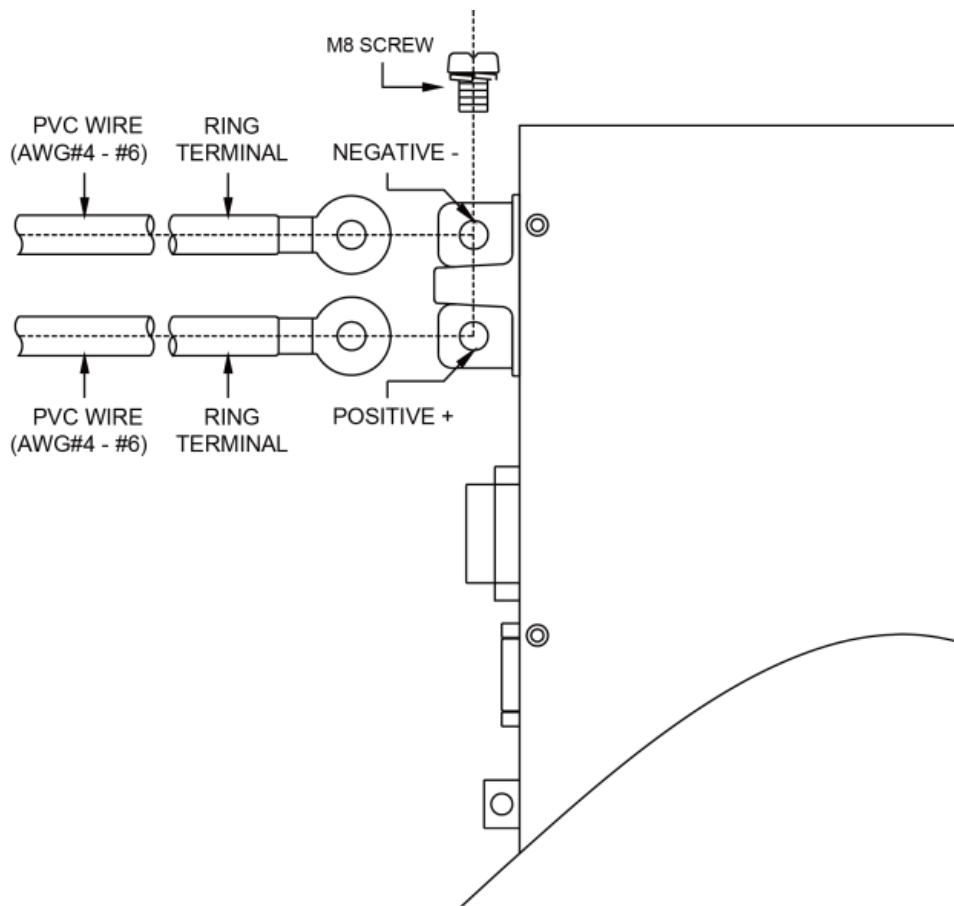

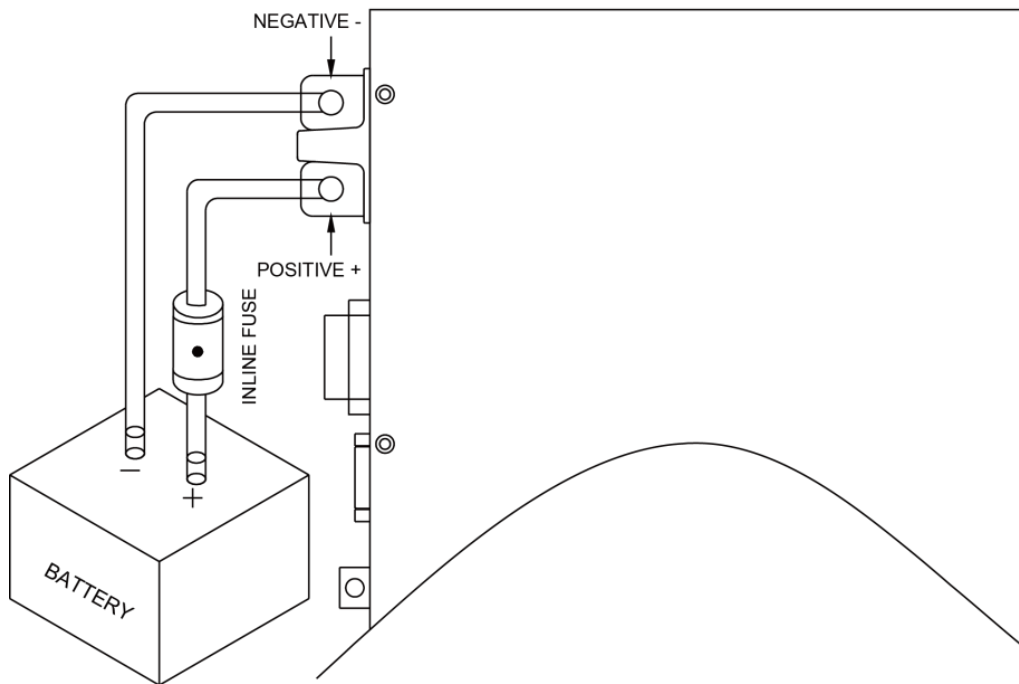

WARNING!

Make sure that all the DC connections are tight (torque to 9 – 10 ft-lbs, 11.7 – 13 Nm). Loose connections could result in overheating and can lead to a potential hazard.



WARNING!

The recommended inline fuse should be installed as close to the battery positive terminal as possible. Failure to use a fuse on the “+” cable running between the inverter and battery may cause damage to the cable / inverter and will void warranty. Consider using Bussmann ANN series fuses.

Protection Mechanism

Model	DC Input (VDC)					Over Temperature Protection	
	Over Voltage		Under Voltage Alarm	Under Voltage		HEAT SINK	
	Shut-down	Restart		Shut-down	Restart	Shut-down	Restart
24V	30.1~34.1	28~32	19~23	18.1~22.1	23~27	105°C	75°C
48V	60.1	56~60	38~46	36.1~44.1	46~54		

3-4. AC wiring connections

- SR1000 : AC socket

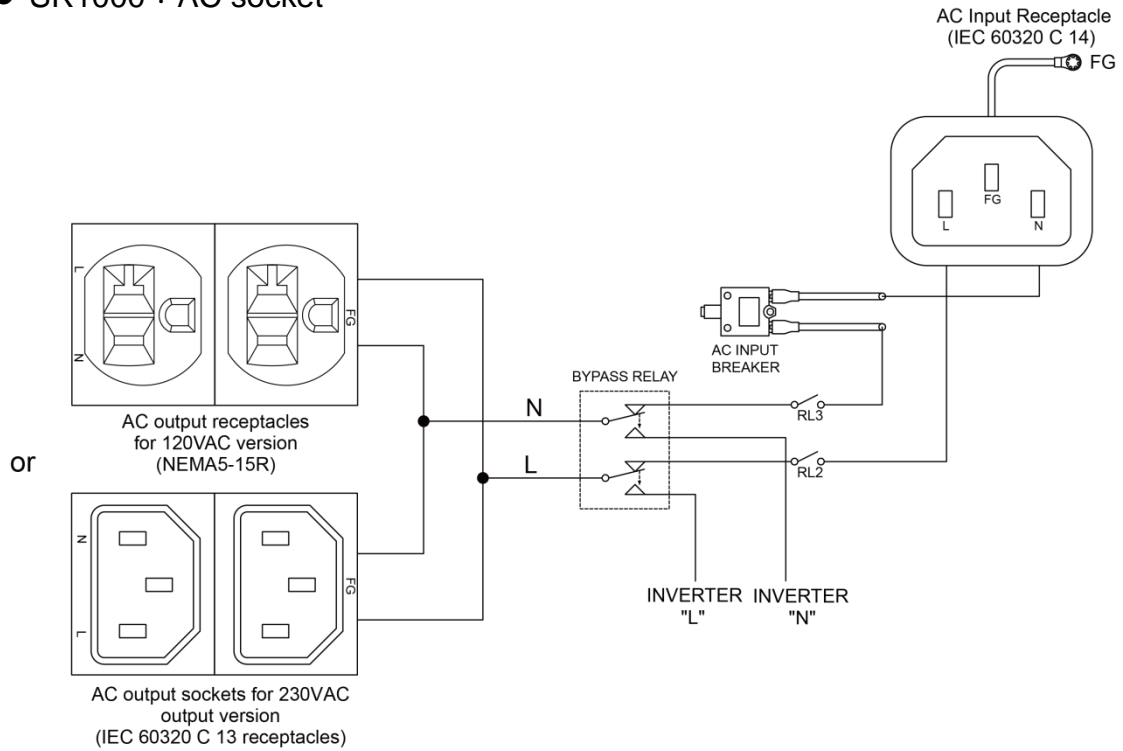

- SR1000T : AC input and AC output terminal

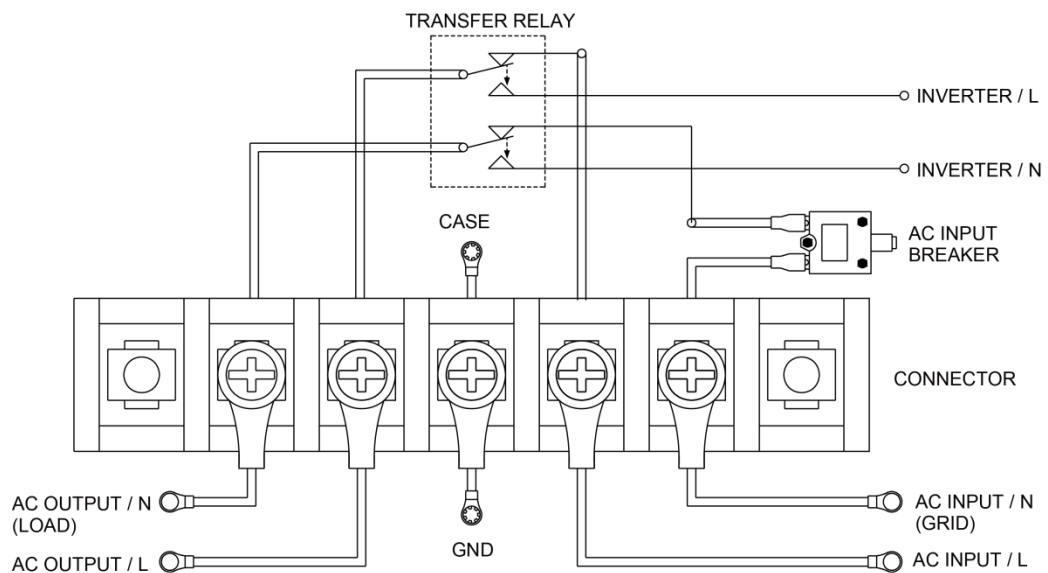

- Connect AC input wiring to the inverter socket.
Please use the following information for reference.

【SR1000T Version】

Socket		Wire color		Wire length / gauge
		120 VAC	230 VAC	
AC Output	Line (L)	Black	Brown	Within 16 feet / AWG # 14~16 26~32 feet / AWG # 12~14
	Neutral (N)	White	Blue	
AC Input	Line (L)	Black	Brown	
	Neutral (N)	White	Blue	
Chassis Ground		Green / Yellow or Bare copper		

Note : Please double check and review all the connections to ensure that the wires are connected to the correct terminals and that the connections are tight.

3-5. Remote control and Dry contact terminal

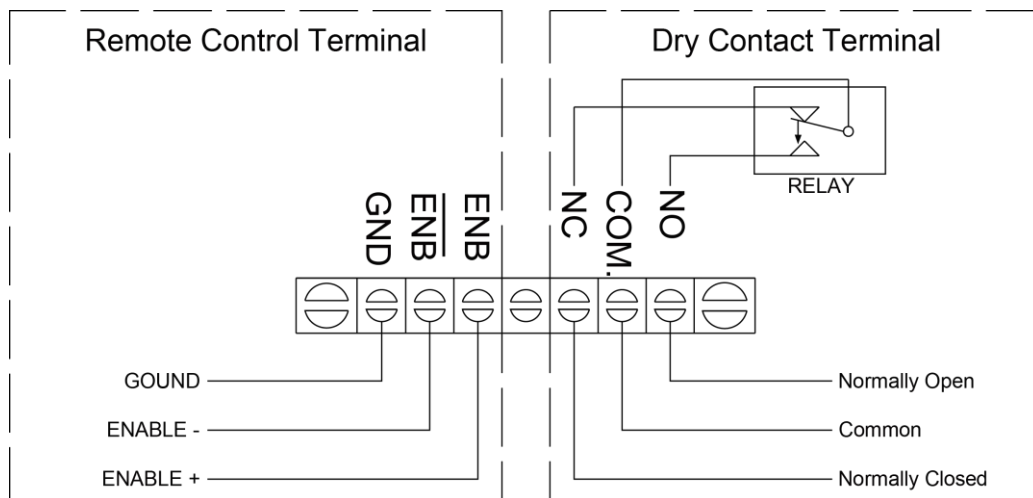

● **Remote Control Terminal :**

1. Before installing the inverter, ensure that the main switch is in the "OFF" position.
2. Before using the remote function, ensure that the main switch is pressed towards "REMOTE".
3. Ensure that the remote contacts are turned off.
4. Use 20 ~ 24 AWG wire to connect the remote control terminals.
5. Remote control ON/OFF inverter setup status :

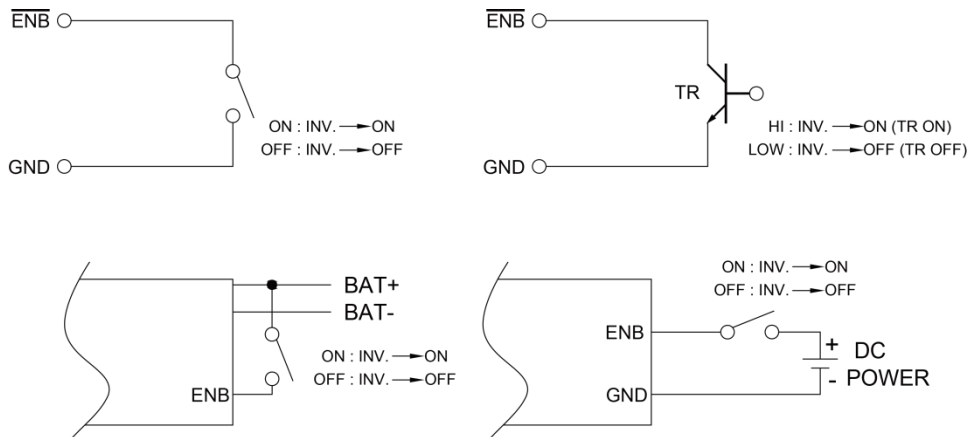

Note : Only one remote function should be used to control the inverter at a time. The maximum voltage value is 60VDC.

Dry Contact Terminal	Relay
COM.	Common contact
N.C.	Normally closed contact
N.O.	Normally open contact

● **Dry Contact Terminals :**

Dry contact terminals can be connected to a Form C relay for "FAULT" indication. When a "FAULT" occurs, the relay switches. Note: Fault conditions include input under/over voltage, output short circuit, over temperature, overload, and fan failure.

Specifications of the Relay

Maximum Voltage	Load	Contact Rating		Number of operations	Operating/Storage Temperature
		N.O.	N.C.		
240 VAC	Resistive	16 A	—	100,000	-30°C~70°C
240 VAC	Resistive	—	8 A	—	
30 VDC	Resistive	16 A	—	—	
30 VDC	Resistive	—	8 A	—	

4. Front LCD Panel – Display & Setup

4-1. LCD Panel Indications

4-1-1. Set the Power Switch to the “ON” position. Inverter will start operating under the normal condition and you can see the status of Vi, Vo, FQ, Io displayed on the LCD screen :

Note: Vi = Input Voltage, Vo=Output Voltage, FQ = Frequency, Io = Output Current

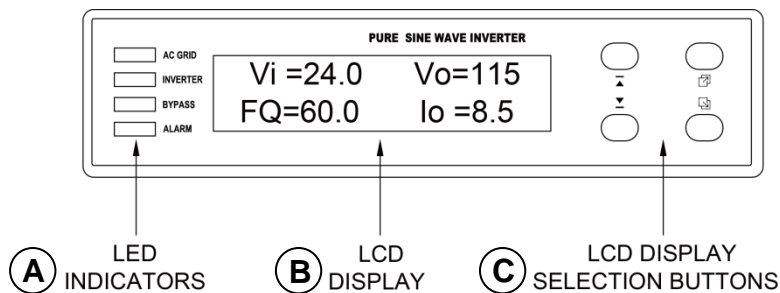



4-1-2. **A** LED INDICATORS : (Refer to 6-1)

4-1-3. **C** LCD DISPLAY SELECTION BUTTONS :

● Function of Various Keys :

 Function <Up> : You can use the “Up” button to scroll through the menu. or to select the value for the set-up under the setting mode.

 Function <Page Up> : You can use the “Page Up” button to scroll up the menu page.

 Function <Page Down> : You can use the “Page Down” button to scroll down the menu page.

 Function <Enter Setup Menu> : Press the button longer than 2 seconds, The inverter will change to “Setup Menu Mode” (the detail in Section 5-3) for the user to set up functions.

Function <Enter> : Confirms a selection or value.

4-1-4. **B** LCD DISPLAY : Displays inverter’s operational status.

4-2. Startup Sequence and Standby Status

4-2-1. Once turn on the inverter, the display shows “SR-1000 INVERTER INITIALIZATION”.

Then. You can check the inverter status as the below flow chart.

Status flow is as follows :

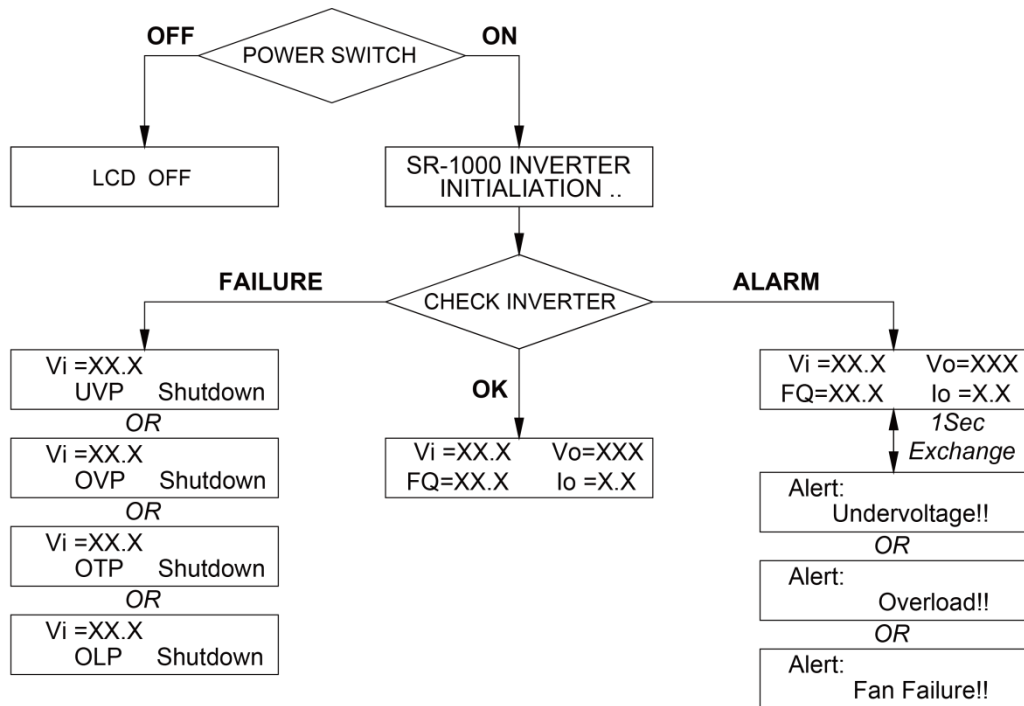

4-3. Setup Menu – Operation and Instructions

Entering Setup Menu :

Press Button  longer than 2 seconds. The inverter, enters the Setup Menus consisting of three layers :

(1)Select Menu Heading : (2)Select Menu Item : (3)Setting Value :

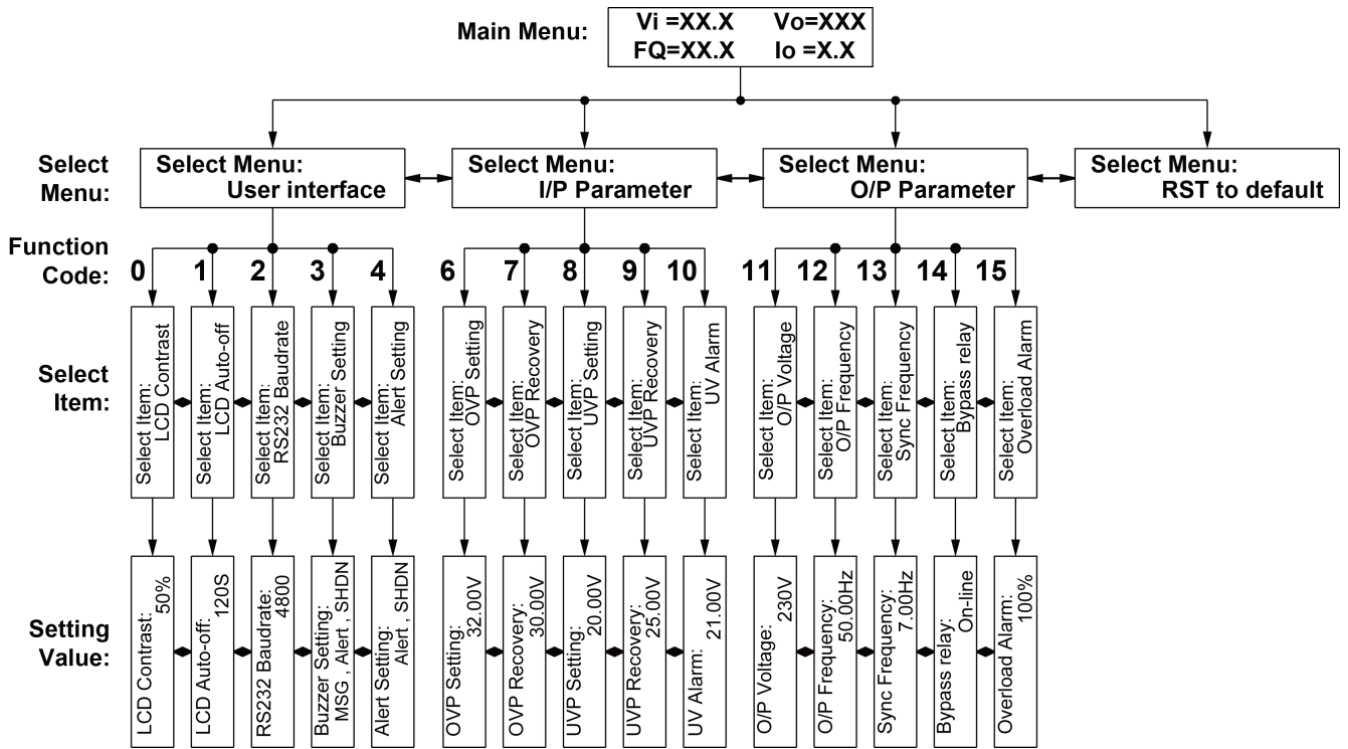

4-3-1. User interface (Select Menu) :

0). **LCD Contrast** : Sets LCD screen contrast.

Default=50%

Setting Range= 0%~100%

1). **LCD Auto-off** : Sets LCD auto off timer.

Default=120 seconds.

Setting Range= Disable~250 seconds.

2). **RS-232 Baud-rate** : Sets standard RS-232 Baud-rate.

Default=4800

Setting Range= 1200/2400/4800/9600

3). **Buzzer Setting** : Sets the internal buzzer sound ON/OFF.

When setting, the LCD screen display, Buzzer “ON”, Buzzer “OFF”.

Default=MSG, Alert, SHDN (Note: MSG = Message, SHDN = Shut Down)

Setting options

1	Disable	4	Alert, SHDN	7	Message, Alert
2	Shutdown	5	Message	8	MSG, Alert, SHDN
3	Alert	6	Message, SHDN		

Note: UV Alarm = Under Voltage Alarm, OVP = Over Voltage Protection, OLP = Overload

Protection, OTP = Over Temperature Protection

- 4). **Alert Setup** : When alert occurs, the internal Dry Contact Relay will open / close. (See details in Section 3-1-6)

Default= Alert, SHDN (Note: SHDN = Shut Down)

Setting options:

1	Disable	2	Shutdown	3	Alert	4	Alert, SHDN
----------	---------	----------	----------	----------	-------	----------	-------------

Definition:

Menu	Status	Relay
Alert	FAN Fail or UV Alarm or Overload Alarm	ON
Shutdown	OVP or UVP or OLP or OTP	ON
Disable	Any	OFF

Note: UV Alarm = Under Voltage Alarm, OVP = Over Voltage Protection, OLP = Overload Protection, OTP = Over Temperature Protection

4-3-2. I/P Parameter (Select Menu) :

- 6). **OVP Setting** : When the DC input voltage is higher than the OVP setting, the inverter shuts down.

Default= 34 VDC for 24V Model, 60 VDC for 48V Model

Model	Setting Value Range
24 V	30 VDC ~ 34 VDC
48 V	60 VDC ~ 68 VDC.

- 7). **OVP Recovery** : When the DC input voltage is higher than the OVP setting, the inverter shuts down; Once the input voltage falls below the set OVP Recovery value, the inverter will be automatically restarted.

Default= 30 VDC for 24V Model, 56VDC for 48V Model

Model	Setting Value Range
24 V	28 VDC ~ 32 VDC
48 V	56 VDC ~ 60 VDC

- 8). **UVP Setting** : When the DC input voltage is lower than the Under Voltage Protection (UVP) setting, the inverter shuts down.

Default= 18 VDC for 24V Model, 36 VDC for 48V Model

Model	Setting Value Range
24 V	18 VDC ~ 22 VDC
48 V	36 VDC ~ 44 VDC

- 9). **UVP Recovery** : When the DC input voltage is below the set UVP value, the inverter shuts down; Once the input voltage rises above the set UVP value, the inverter will be automatically restarted.

Default= 25 VDC for 24 V Model, 50 VDC for 48 V Model

Model	Setting Value Range
24 V	23 VDC ~ 27 VDC
48 V	46 VDC ~ 54 VDC

- 10). **UV Alarm** : Sets Under Voltage (UV) alarm. When the input voltage is lower than the set value, the unit will sound “beep” to remind that the unit is going to shut down. In the meantime, the contact in the internal Dry Contact Relay will open / close (See details in Section 3-1-6 AC wiring connections).

Default= 21 VDC for 24V Model, 42 VDC for 48V Model

Model	Setting Value Range
24 V	19 VDC ~ 23 VDC
48 V	38 VDC ~ 46 VDC

Note : The value of voltage set for the “UV Alarm” should be equal to or higher than the value set for “UVP” or else the unit will shut down without any audible warning.

4-3-3. Output (O/P) Parameters :

- 11). **O/P Voltage** : Set the inverter output voltage.

Default= 110 VAC for 110V Model, 230 VAC for 220V Model

Model	Setting Value Range
110V	97 VAC ~ 123 VAC
220V	194 VAC ~ 246 VAC

- 12). **O/P Frequency** : Set the inverter output frequency.

Default= 60 Hz for 110V Model, 50 Hz for 220V Model.

Model	Setting Value Range
110V	47 Hz ~ 63 Hz
220V	47 Hz ~ 63 Hz

- 13). **Sync Frequency** : Sets the AC output synchronous frequency.

Example : AC input= 230 VAC / 50Hz, User setting Value= 7Hz

When the DC to AC inverter “Frequency” is within The Range of 43 Hz~57 Hz, the internal bypass relay will operate normally. When the “Frequency” is less than 43 Hz or more than 58 Hz, the internal bypass relay will de-energize.

(See details in Section 2-2)

Default= 0.1Hz ~ 7Hz.

Model	Setting Value Range
110V	0.1 Hz ~ 7 Hz
220V	0.1 Hz ~ 7 Hz

14). **Bypass Relay** : The setup is provided in one of the following two ways : On line Mode or Off line Mode (Exacting, Normal, Haphazard).

Default= Normal (Off line).

Mode	Menu	Bypass Relay Switching Feature
OFF LINE (See details in Section 5-3)	Exacting	The bypass relay will switch "ON" or "OFF" based on conformance to, the Phase and Sync Frequency window that has been set (Function Code 13)
	Normal	The bypass relay will be "ON" if AC input (Grid) power is available. The DC-AC inverter will remain synchronized and Phase with the incoming AC power (Grid). The relay will NOT switch off if the grid frequency is beyond the range set under Sync Frequency window (Function Code 13).
	Haphazard	The bypass relay will switch "ON" or "OFF". Conformance to, phase and frequency synchronization will not be considered.
ON LINE	—	(See details in Section 5-3)

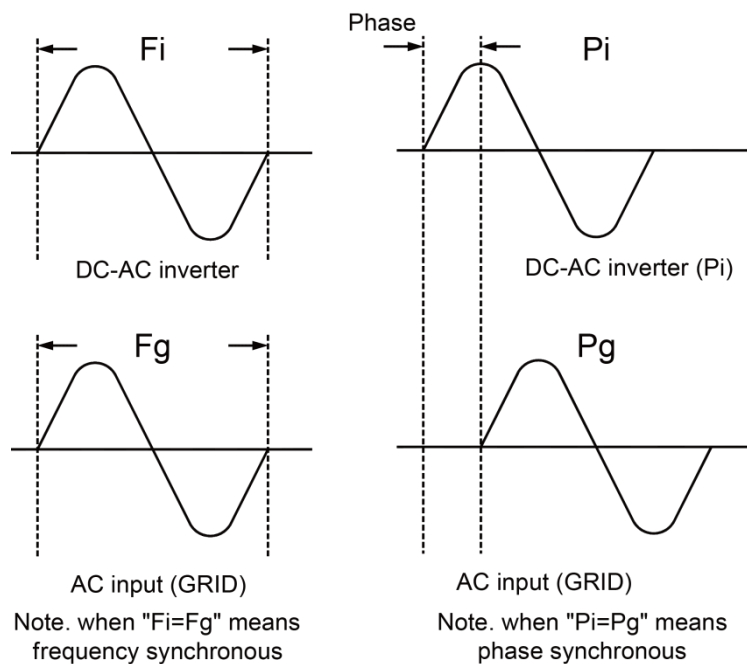

15). **Overload Alarm** : Sets the overload alarm. When the output power is higher than the set value, the unit will sound “beep” to remind that the unit is going to shutdown. At the same time, the internal Dry Contact Relay will open/close (See details in Section 3-1-6).

Default= 100%

Setting range= 50%~110%

5. RS-232 Communication and Operation

5-1. Operation of RS-232 Serial Port

5-1-1. This unit uses a standard 9-Pole D connector and three of the RS-232 signal lines :

Signal description	PIN
N.C	1
RXD	2
TXD	3
DTR	4
GND	5
DSR	6
RTS	7
CTS	8
N.C	9

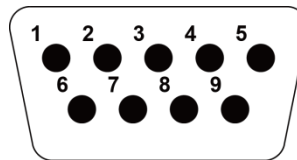

5-1-2. The connection between this unit and the computer is as follows :

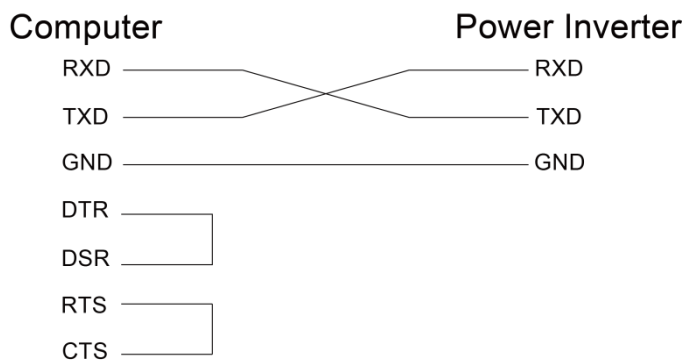

5-1-3. The RS-232 interface of this unit employs ASCII code to implement the asynchronous serial transmission control.

The byte structure is START-BIP – 8 BIT DATA-STOP BIT.

Baud rate : 1200/2400/4800/9600(See details in Section 5-3-1).

5-1-4. Coupled with PC software application port. Operation is as detailed in Section 5-2.

5-2. Interface Commands

The RS-232 port of this unit has a buffer size of 12 bytes. Any bytes exceeding this value will be ignored. The unit uses the DTR line to indicate its readiness to receive data from the computer. Before sending information to the unit, the computer should check the DTR line. The unit is typically always ready to receive data during operation. When a LF character (ASCII code 0AH) is received, the unit will finish receiving by clearing the DTR status and start interpreting the received information. If the received command or data is correct, the unit will execute it. Regardless of the acceptance of the command, the unit will always send a response signal to the computer and set DTR to ready for receiving more incoming information.

5-2-1. For the RS-232 interface, the baud rate can be configured using the Setup Menu. Refer to Section 5-3-1 for detailed instructions.

Note: that you need to reset the unit after adjusting the baud rate to activate the new setting.

5-3. Example of the RS-232 Operation

5-3-1. RS-232 command :

Command format :

This unit uses high-level language commands with a CR (0DH) and LF (0AH) as the end of the command.

The system would interpret and execute the command only after these two characters are received. After the unit executes the command, it would send a response string to the computer. The response string is as follows :

= > CR LF : Command executed successfully

? > CR LF : Command error, not accepted

! > CR LF : Command correct but execution error (e.g. parameters out of range).

If the command needs any information from the unit, the unit would send the information back to the computer (with CR and LF) and then send the response string to the computer.

5-3-2. Command format :

This unit supports the following command format.

There should always be a CR (0DH) and a LF (0AH) appended to the command while sending the command to this unit.

1). Command to switch the Power ON/OFF :

Format : Power <value>

Example : A space (ASCII code 20H) is needed between Power and <value>.
<value> can be one of the following.

“0” : Power off

“1” : Power on

2). Command to query the Output Frequency :

Format : FRQ?

After “Enter”, the unit’s “Output Frequency” appears on the PC screen.

3). Command to query the Output Voltage :

Format : VOL?

After “Enter”, the unit’s “Output Voltage” appears on the PC screen.

4). Command to query the Output Current :

Format : AMP?

After “Enter”, the unit’s “Output Current” appears on the PC screen.

5). Command to query the Input Battery Voltage :

Format : BAT?

After “Enter”, the unit’s “Input Voltage” appears on the PC screen.

5-3-3. Command for accessing Setup Menus and adjusting values :

1). Select the Setup Menus with the help of Function Codes :

Format : FUNC <Function Code>

After “Enter”, the Setup Menu for the Function Code will be called.

The <Function Code>= 0~17, as follows :

<Function Code>	Setting Menu	<Function Code>	Setting Menu
0	LCD Contrast	9	UVP Recovery
1	LCD Auto-off	10	UV Alarm
2	RS-232 Baud-rate	11	O/P Voltage
3	Buzzer Setting	12	O/P Frequency
4	Alert Setting	13	Sync Frequency
5	NOT USED	14	Bypass Relay
6	OVP Setting	15	Overload Alarm
7	OVP Recovery	16	NOT USED
8	UVP Setting	17	NOT USED

2). Command to query the Functions No :

Format : FUNC?

After “Enter”, the unit’s “Function Code” appears on the PC screen.

3). Command to query the set value of the Function :

Format : SETT?

After “Enter”, the existing set value of the function appears on the PC screen.

4). Command to set or adjust the value of the Function :

Format : SETT <value>

After “Enter”, the new value of the Function is set Choose the <value> of the function as follows :

FUNC 0 : LCD Contrast

Setting Menu	SETT <value>
LCD Contrast	0~100

FUNC 1 : LCD Auto-off

Setting Menu	SETT <value>
LCD Auto-off	Disable~250

FUNC 2 : RS-232 Baud rate

Setting Menu	SETT <value>	Baud rate
RS-232 Baud rate	0	1200
	1	2400
	2	4800
	3	9600

FUNC 3 : Buzzer Setting

Setting Menu	SETT <value>	Buzzer (Beep sound)
Buzzer Setting	0	Disable
	1	Shutdown
	2	Alert
	3	Alert , SHDN
	4	Message
	5	Message , SHDN
	6	Message , Alert
	7	Msg , Alert , SHDN

FUNC 4 : Alert Setting

Setting Menu	SETT <value>	Alert
Alert Setting	0	Disable
	1	Shutdown
	2	Alert
	3	Alert , SHDN

FUNC 6 : OVP Setting

Setting Menu	SETT <value>	Model
OVP Setting	30~34	SR1000/SR1000T-124
		SR1000/SR1000T-224
	60 MAX.	SR1000/SR1000T-148
		SR1000/SR1000T-248

FUNC 7 : OVP Recovery

Setting Menu	SETT <value>	Model
OVP Recovery	28~32	SR1000/SR1000T-124
		SR1000/SR1000T-224
	56~60	SR1000/SR1000T-148
		SR1000/SR1000T-248

FUNC 8 : UVP Setting

Setting Menu	SETT <value>	Model
UVP Setting	18~22	SR1000/SR1000T-124
		SR1000/SR1000T-224
	36~44	SR1000/SR1000T-148
		SR1000/SR1000T-248

FUNC 9 : UVP Recovery

Setting Menu	SETT <value>	Model
UVP Recovery	23~27	SR1000/SR1000T-124
		SR1000/SR1000T-224
	46~54	SR1000/SR1000T-148
		SR1000/SR1000T-248

FUNC 10 : UV Alarm

Setting Menu	SETT <value>	Model
UV Alert	19~23	SR1000/SR1000T-124
		SR1000/SR1000T-224
	38~46	SR1000/SR1000T-148
		SR1000/SR1000T-248

FUNC 11 : O/P Voltage

Setting Menu	SETT <value>	Model
O/P Voltage	97~123	SR1000/SR1000T-124
		SR1000/SR1000T-148
	194~246	SR1000/SR1000T-224
		SR1000/SR1000T-248

FUNC 12 : O/P Frequency

Setting Menu	SETT <value>
O/P Frequency	47~63

FUNC 13 : Sync Frequency

Setting Menu	SETT <value>
Sync Frequency	0.1~7

FUNC 14 : Bypass Relay





Setting Menu	SETT <value>	Alert
Bypass Relay	0	ON LINE
	1	Haphazard (OFF LINE)
	2	Normal (OFF LINE)
	3	Exacting (OFF LINE)

FUNC 15 : Overload Alarm

Setting Menu	SETT <value>
Overload Alarm	50~110

6. LED Status Description & Trouble shooting

6-1. LED Status Description

LED Indicator	AC GRID	INVERTER	BYPASS	ALARM
 Green	*The AC input power and the inverter output power are synchronized	Power OK	AC input bypass (AC mode)	
 Orange	AC input power is being detected		DC-AC inverter (DC mode)	**DC Over Voltage DC Under Voltage FAN Alarm
 Red		Power Not Good		
 Off	AC input power is off		AC input power is off	

*The grid AC input frequency and DC-AC inverter output frequency and phase are the same

** For instructions on setting the alarm, see details in Section 4-3

6-2. Troubleshooting



WARNING!

Do not open or disassemble the SR series Inverter.

Attempting to service the unit may cause risk of electrical shock or fire.

Problems and Symptoms	Possible Cause	Solutions
<i>No AC Power "Output"</i>		
a. LCD Panel Display "OLP Shutdown"	Short circuit, wiring error. over loading.	Check AC wiring for short circuit. Reduce load.
b. LCD Panel Display "OVP Shutdown"	Over input voltage (OVP)	Check input voltage. Reduce input voltage.
c. LCD Panel Display "UVP Shutdown"	Low input voltage. (UVP)	Recharge battery. Check connections and cables.
d. LCD Panel Display "OTP shutdown"	Thermal shutdown. (OTP)	Improve ventilation. Make sure ventilation, grilles / slots of the inverter are not obstructed. Lower ambient temperature.

7. Warranty

We guarantee this product against defects in materials and workmanship for a period of 24 months from the date of purchase. If you experience any issues, please return the defective power inverters directly to us with postage paid, and we will repair or replace them.

Please note that COTEK is responsible for ensuring the proper functionality of our products before delivery. However, this warranty will be void if the unit has been misused, altered, or accidentally damaged. COTEK cannot be held liable for any issues that arise due to user error.

COTEK

No.33, Sec. 2, Renhe Rd., Daxi Dist., Taoyuan City 33548, Taiwan

Phone : +886-3-3891999 FAX : +886-3-3802333

[http : // www.cotek.com.tw](http://www.cotek.com.tw)

2026.01_A5